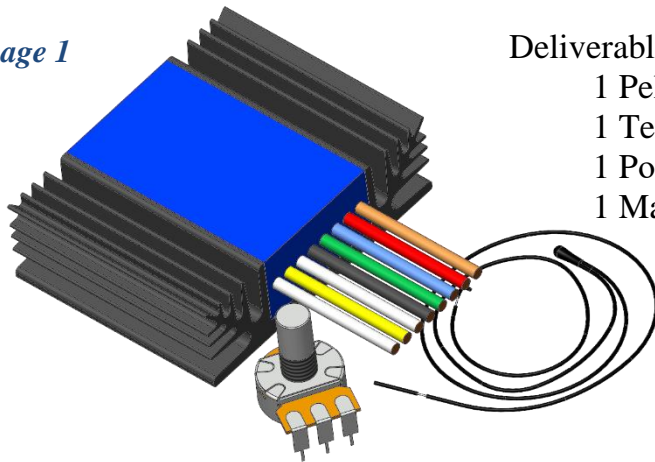

## Manual QC-PC-C01C

### Temperature controller for peltier cooling applications

*Image 1*

Deliverables:

- 1 Peltier controller QC-PC-C01C
- 1 Temperature sensor NTC 10K $\Omega$  ( $\beta=3977K$ )
- 1 Potentiometer 10K $\Omega$
- 1 Manual



#### Technical specifications:

Dimensions	65mm x 50mm x 20mm
Temperature range:	-20°C...+50°C
Voltage supply:	10V...24V
Max. output voltage:	corresponding to input voltage
Max. output current:	10A

### 1. Intended use of the controller QC-PC-C01C

The controller QC-PC-C01C has been developed to cool down an object aided by a Peltier element and to keep the temperature constant. A prerequisite for this is a thermal structure that is shown in *Image 2*. The controller is operated with low voltage and must never be connected to the mains voltage. Electrical wiring must be carried out in order to set up a functioning control system. This requires basic electrical knowledge. Only work on the wiring when the supply is switched off. Bear in mind that the controller and controlled components can be destroyed if they are used improperly. In spite of the low input voltage, high currents occur, which lead to considerable heating of incorrectly executed contact files and thin cables. These faulty connections can cause fires.

Therefore, please read these operating instructions carefully. If you are not specialized, you should definitely be instructed by a qualified electrician. If you notice any warming within the wiring at any point in time, the circuit must be de-energized immediately. Regulators and Peltier elements will work for a long time, only if you adhere to the following instructions.

## 2. The thermal design

The Peltier element is able to transfer thermal energy from one side to the other. As a result, the temperature decreases where the energy is extracted and increases where this energy is transferred. In order to make this "heat pump" usable, a structure as shown in [Image 2](#) must be set up.

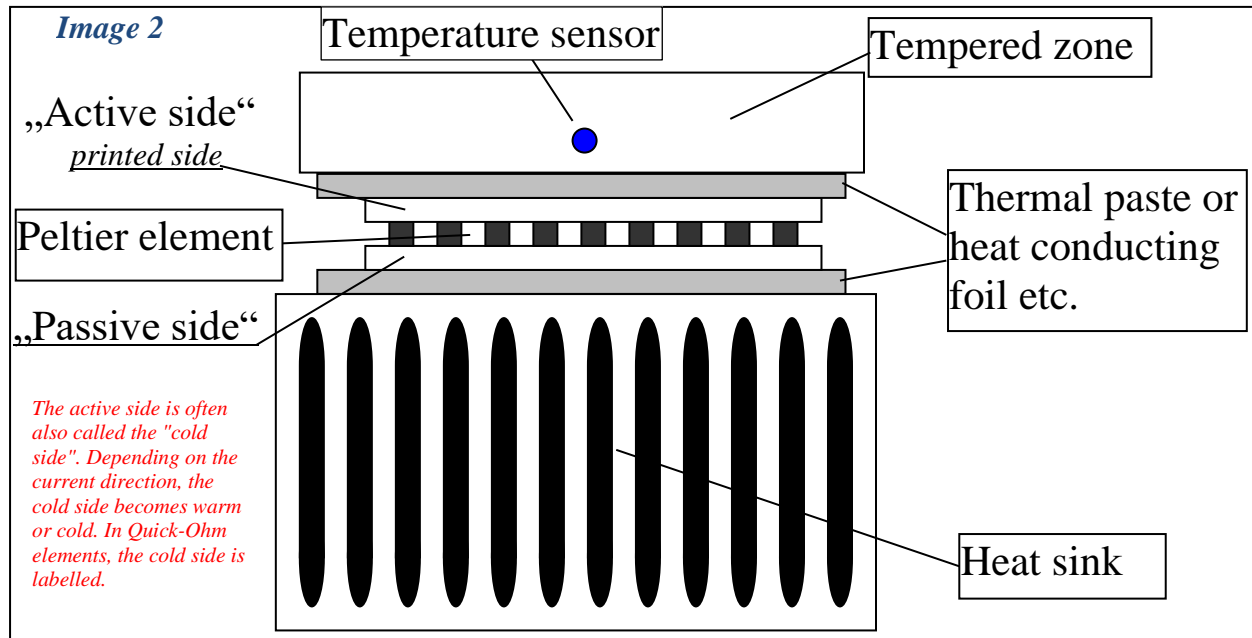

[Image 2](#) shows the basic structure of the peltier temperature control. The active side is the zone that is to be brought to a desired temperature with a peltier element. The "cold side" of the peltier element is attached here. If current is now passed through the element, a heat flow occurs, which in turn causes a temperature difference between the two sides of the peltier element. The size of this temperature difference is in turn influenced by other factors, such as heat flow and temperature. If the connected heat capacity of one side dominates, then the temperature difference mentioned primarily controls the temperature of the other side. This is exactly what a correctly dimensioned heat sink achieves. The heat sink keeps the passive side temperature close the cooling medium. Only then the temperature difference changes the temperature of the peltier side where it is required. Without a heat sink, the zone to be tempered dominates. A controlled current will then only change the temperature of the open passive side. The design of this heat sink and the proper contact between the individual components are primarily what determine the performance of your set-up. Please always focus your attention on this basic design, only then your results can be successful. To deepen your knowledge, please visit the section [Library](#) in Thermal Management on our homepage. Here you will find tips and information in an easy-to-understand and well-illustrated form.

### 3. The electrical wiring

Please note that no current or voltage limits can be set in the controller. This means that the controller passes on the full voltage to the Peltier element at maximum cooling demand, i.e., when the target temperature is far above the current temperature.

Therefore, make sure that the supply voltage does not exceed the maximum permissible voltage of your Peltier element, or connect several Peltier elements in series until the sum of the individual voltages reaches at least the value of the supply voltage. Please observe the mesh rules of electrical engineering. Likewise, select the load so that the maximum permissible current of 10 amperes is not exceeded. *Image 3* shows the wiring of the individual components of the control circuit. The colours correspond to the wire colours of the controller.

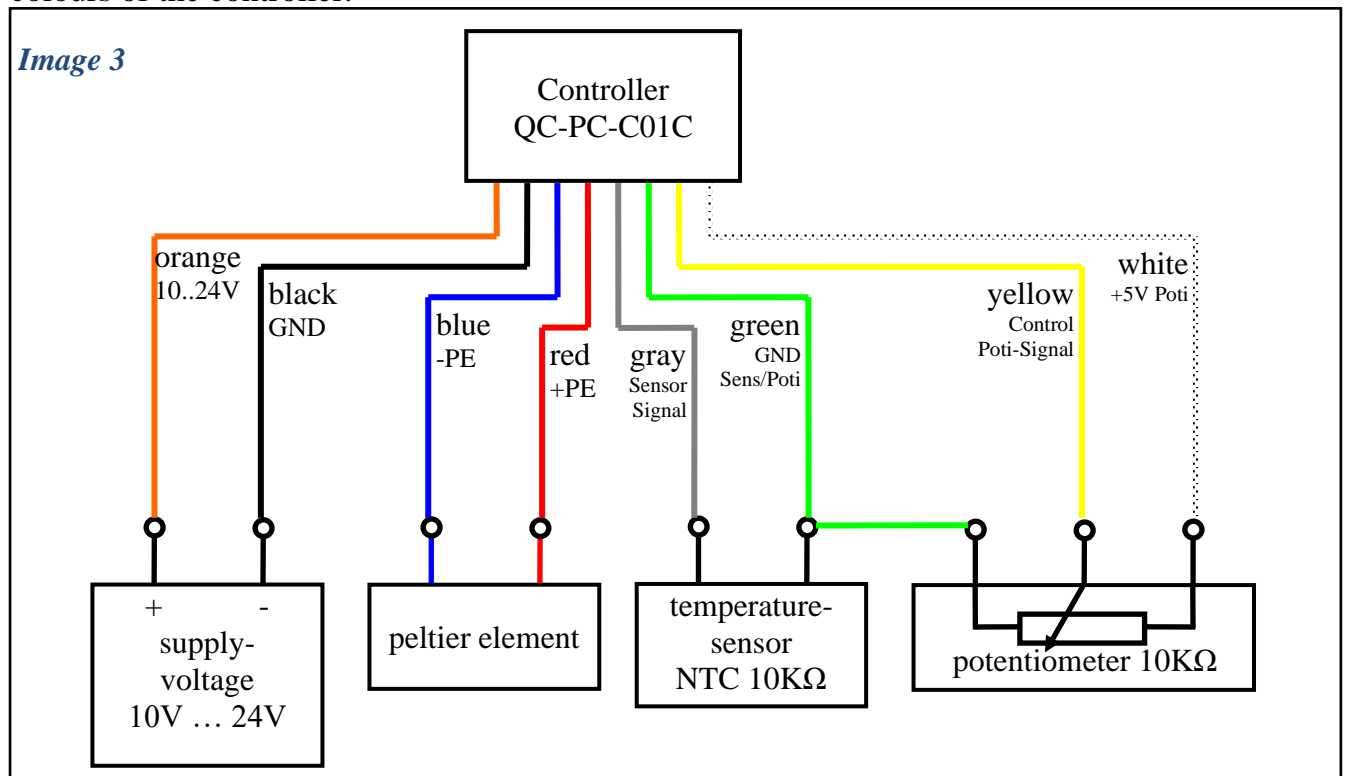

If you follow this circuit diagram and use Peltier elements from QUICK-OHM, the printed side will be cold and the blank side will be warm.

### 4. Adjusting the temperature

The temperature is set via the potentiometer. The controller regulates the temperature in a range from  $-20^{\circ}\text{C}$  to  $+50^{\circ}\text{C}$ . Please note that the controller can only cool. This means that only temperatures lower than the temperature on the passive side are achieved. If the display ([QC-PC-D-100](#)) is connected, the target temperature and the temperature measured at the sensor can be seen. The controller works even without the display.

However, since no temperature setpoint can be read from the potentiometer position, the potentiometer should then be scaled.

## 5. The control character

The controller has a pure P-control characteristic. As long as the actual temperature is clearly above the set temperature, the output is fully controlled and the Peltier element is activated with the full supply voltage. When the setpoint is approached, the output is reduced (PWM<100%). If the actual value falls below the setpoint, the output is switched off (PWM=0%). If the structure is fully controlled, a control deviation always remains for the P-control.

## 6. Tips

1. The heat sink (*Image 2*) must be able to dissipate the sum of transported thermal energy and electrical energy. If the heat sink temperature rises significantly above the ambient temperature, then the heat sink is undersized. In this case, it must be enlarged or a stronger fan must be used. As a rule, cooling by means of peltier elements always requires a fan.
2. Sensor: [QC-TE-BU-350](#) (Scope of delivery): The sensor must be inserted into a hole (Ø2.5mm) for correct measurement. Heat conductive paste must be inserted into the hole. Placing the supplied sensor on a surface achieves incorrect measured values and makes functioning control impossible.
3. The control electronics are embedded in a heat sink (see *Image 4* below) If this heat sink heats up considerably, it must be cooled with an air stream or contacted with another heat sink. The heat sink is used for cooling the power transistors and cannot be used for cooling the Peltier element.

*Image 4*

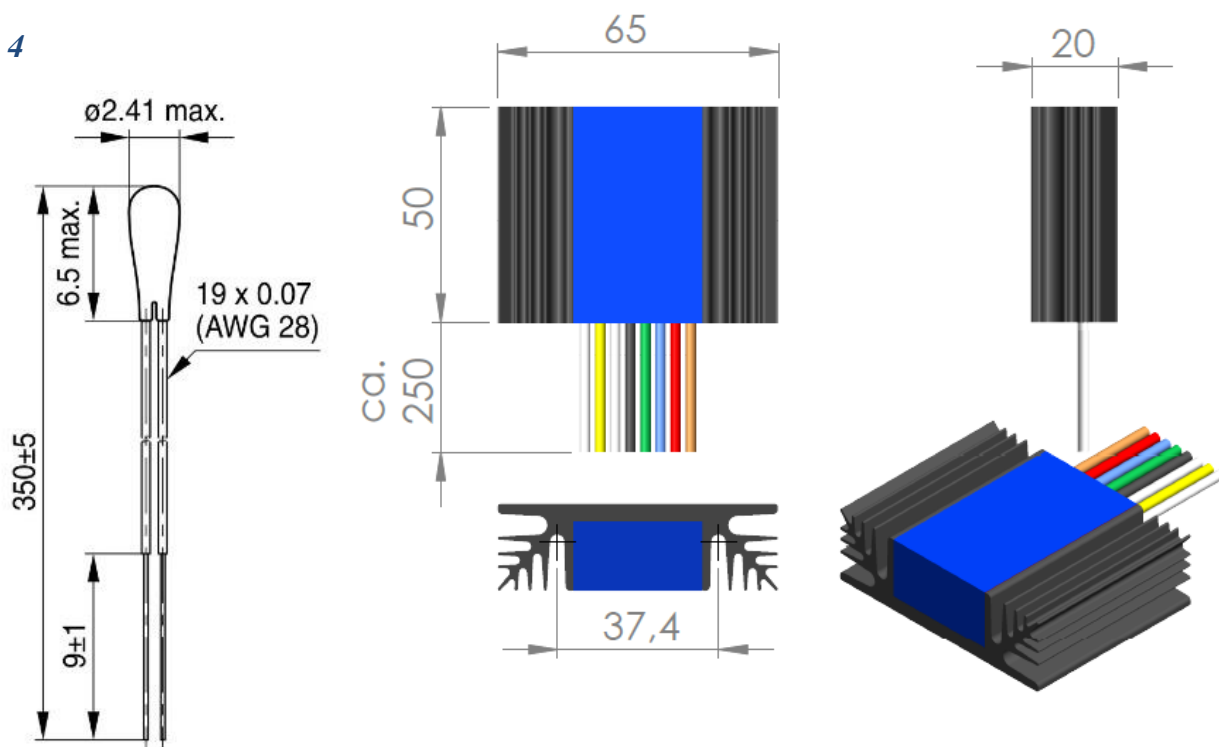

Sensor: [QC-TE-BU-350](#)

Controller: QC-PC-C01C